



STEELER

SOKÓŁKA

www.steeler.pl

SKODA KODIAQ 2016



INSTRUKCJA MONTAŻU

(Orurowania przednie)

FITTING INSTRUCTION

(Front bullbar)

Инструкция монтажа

(кенгурин широкий)

MONTAGEANLEITUNG

(Chutzbügel)

KODIAQ-N1660-09

KODIAQ-N1660-10









Orurowania z homologacją „e”

Bullbar with homologation „e”

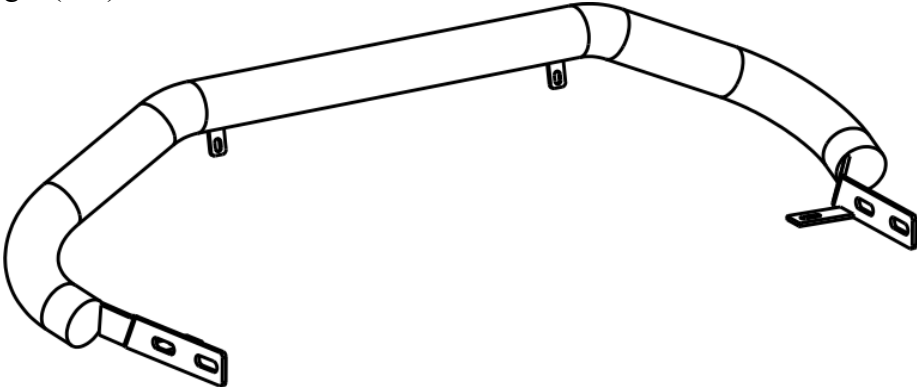
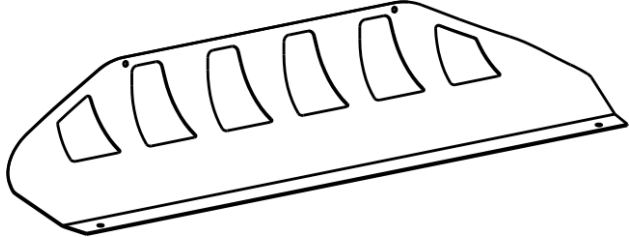
Тюнинг с омологацией „e”

Frontschutzbügel mit „e“- Prüfzeichen

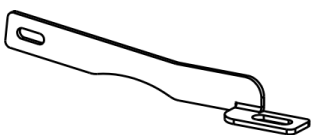
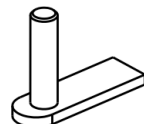
Wykaz elementów orurowania:
Specification of full assembly:
Список элементов тюнинга:
Liste der Elemente:

| | |
|---|---|
| <p>1. Rura przednia (szt. 1) Bullbar (1 pc.) Передняя дуга (шт.1) Frontbügel (st.1)</p> |  |
| <p>2. Blacha dolna (szt. 1) Lower metal plate (1 pc.) Защита картера (шт.1) Unterfahrschutz (st.1)</p> |  |
| <p>3. Zamocowanie dolne I (szt. 2) Lower attachment I (2 pcs.) Крепление нижнее I (шт.2) Montage unten I (st.2)</p> |  |
| <p>4. Zamocowanie dolne II (szt. 2) Lower attachment II (2 pcs.) Крепление нижнее II (шт.2) Montage unten II (st.2)</p> |  |
| <p>5. Zamocowanie dolne lewe III (szt. 1) Lower left attachment III (1 pc.) Крепление нижнее левое III (шт.1) Montage unten links III (st.1)</p> |  |
| <p>6. Zamocowanie dolne prawe III (szt. 1) Lower right attachment III (1 pc.) Крепление нижнее правое III (шт.1) Montage unten rechts III (st.1)</p> |  |
| <p>7. Szpilka M12x45 (szt. 2) Skewer M12x45 (2 pcs.) Шпилька M12x45 (шт.2) Stecknadel M12x45 (st.2)</p> |  |
| <p>8. Podkładka (szt. 2) Washer (2 pcs.) Шайбы (шт. 2) Unterlegscheiben (st. 2)</p> |  |

Wykaz elementów łącznych:
Connecting components:
Список соединительных элементов:
Die Auflistung der Elemente:

KODIAQ-N1660-09

| | | | |
|--|--|---|------------------------------------|
| Śruby (szt.) Screws (pcs.) Болты (шт.) Schrauben (st.) | M8x30 – (2) M10x30 – (6) M12x45 – (2) (szpilka – skewer) | Nakrętki (szt.) Nuts (pcs.) Гайки (шт.) Muttern (st.) | M8 – (2) M10 – (6) M12 – (2) |
| Podkładki (szt.) Washers (pcs.) Шайбы (шт.) Unterlegscheiben(st.) | Ø 8 – (4) – XL Ø 8 – (2) – SPR Ø 10 – (12) – XL Ø 10 – (6) – SPR Ø 12 – (2) – XL Ø 12 – (2) – SPR |  13 17 19 | |

KODIAQ-N1660-10

| | | | |
|--|---|--|--|
| Śruby (szt.) Screws (pcs.) Болты (шт.) Schrauben (st.) | M6x20 – (4) M8x30 – (2) M10x30 – (6) M12x45 – (2) (szpilka – skewer) | Nakrętki (szt.) Nuts (pcs.) Гайки (шт.) Muttern (st.) | M6 – (4) M8 – (2) M10 – (6) M12 – (2) |
| Podkładki (szt.) Washers (pcs.) Шайбы (шт.) Unterlegscheiben(st.) | Ø 6 – (4) – XL Ø 6 – (4) – SPR Ø 8 – (4) – XL Ø 8 – (2) – SPR Ø 10 – (12) – XL Ø 10 – (6) – SPR Ø 12 – (2) – XL Ø 12 – (2) – SPR |  10 13 17 19 | |

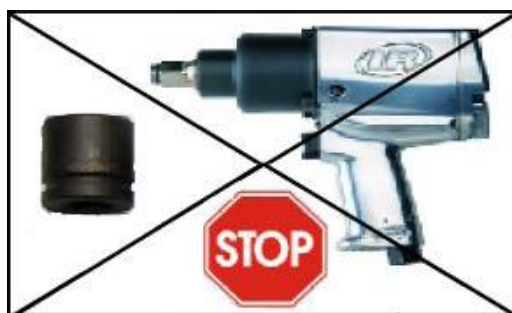

1 h

Czas montażu
Fitting time
Время монтажа
Montagezeit

| | | | |
|------------------|-------------------|--------------------|--------------------|
| M6 - 7 Nm | M8 - 17 Nm | M10 - 33 Nm | M12 - 57 Nm |
|------------------|-------------------|--------------------|--------------------|

UWAGA: Folię usunąć dopiero po montażu!

ATTENTION: Foil remove after fitting!

ВНИМАНИЕ: Целлофан снять только после завершения монтажа!

HINWEIS: Die Folie soll erst nach der Montage entfernt werden!

Montaż orurowania / Bullbar fitting / Монтаж защиты / Montage der Schwellerrohre
KODIAQ-N1660-09

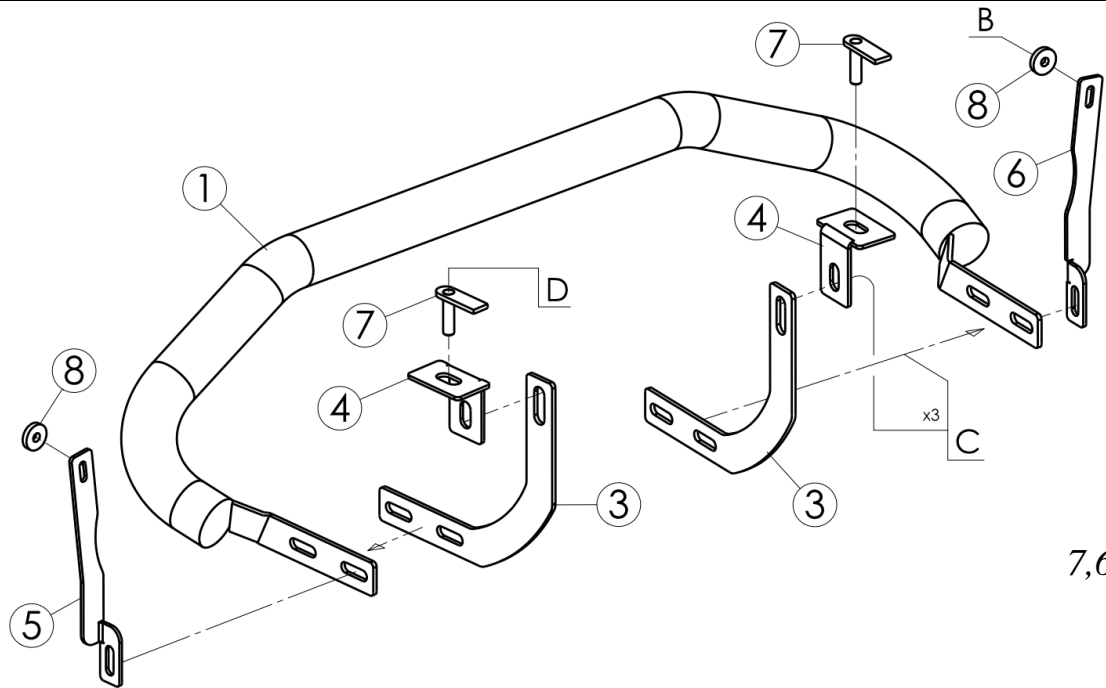

7,6 kg

Montaż orurowania / Bullbar fitting / Монтаж защиты / Montage der Schwellerrohre
KODIAQ-N1660-10

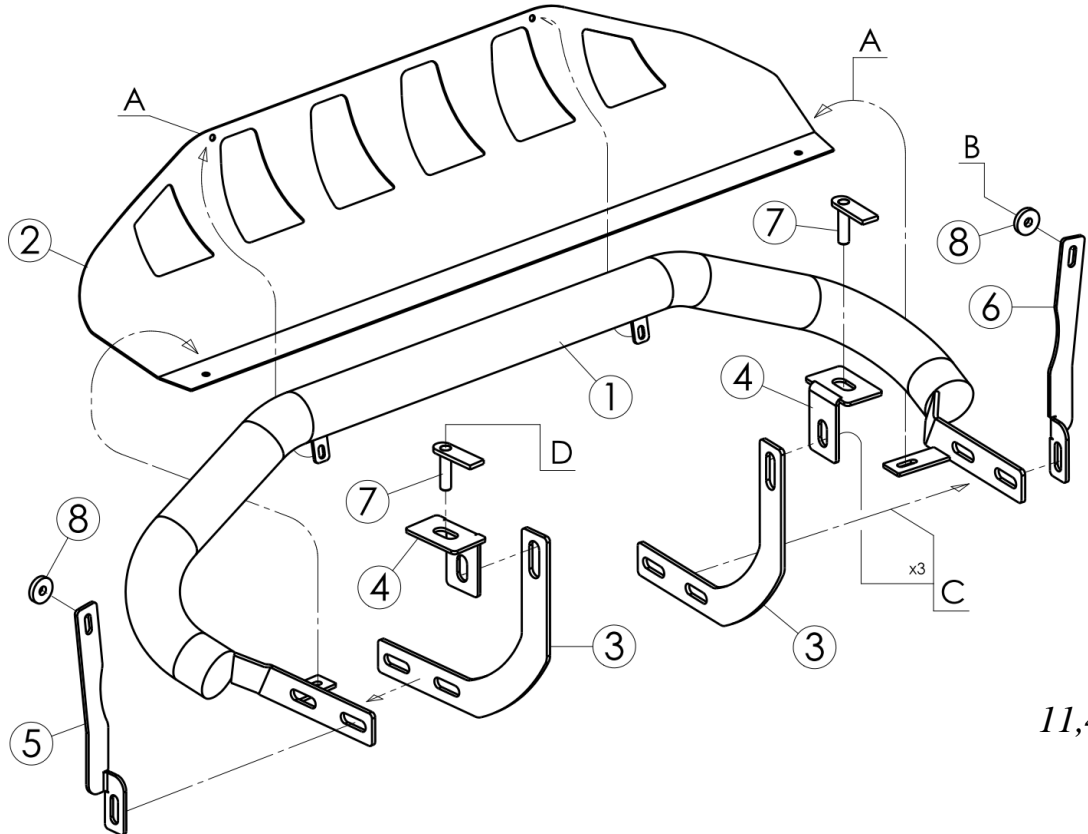

11,4 kg

| | Śruby (szt.) Screws (pcs.) Болты (шт.) Schrauben (st.) | Podkładki (szt.) Washers (pcs.) Шайбы (шт.) Unterlegscheiben (st.) | Nakrętki (szt.) Nuts (pcs.) Гайки (шт.) Muttern (st.) |
|----------|---|---|--|
| A | M6x20 | Ø6-XL, Ø6-SPR | M6 |
| B | M8x30 | Ø8-XL(x2), Ø8-SPR | M8 |
| C | M10x30 | Ø10-XL(x2), Ø10-SPR | M10 |
| D | M12x45 | Ø12-XL, Ø12-SPR | M12 |

D – szpilka / skewer / шпилька / Stecknadel

*Lewa część orurowania / Left attachments / Левая часть защиты
/Linke Seite des Frontschutzbügels*

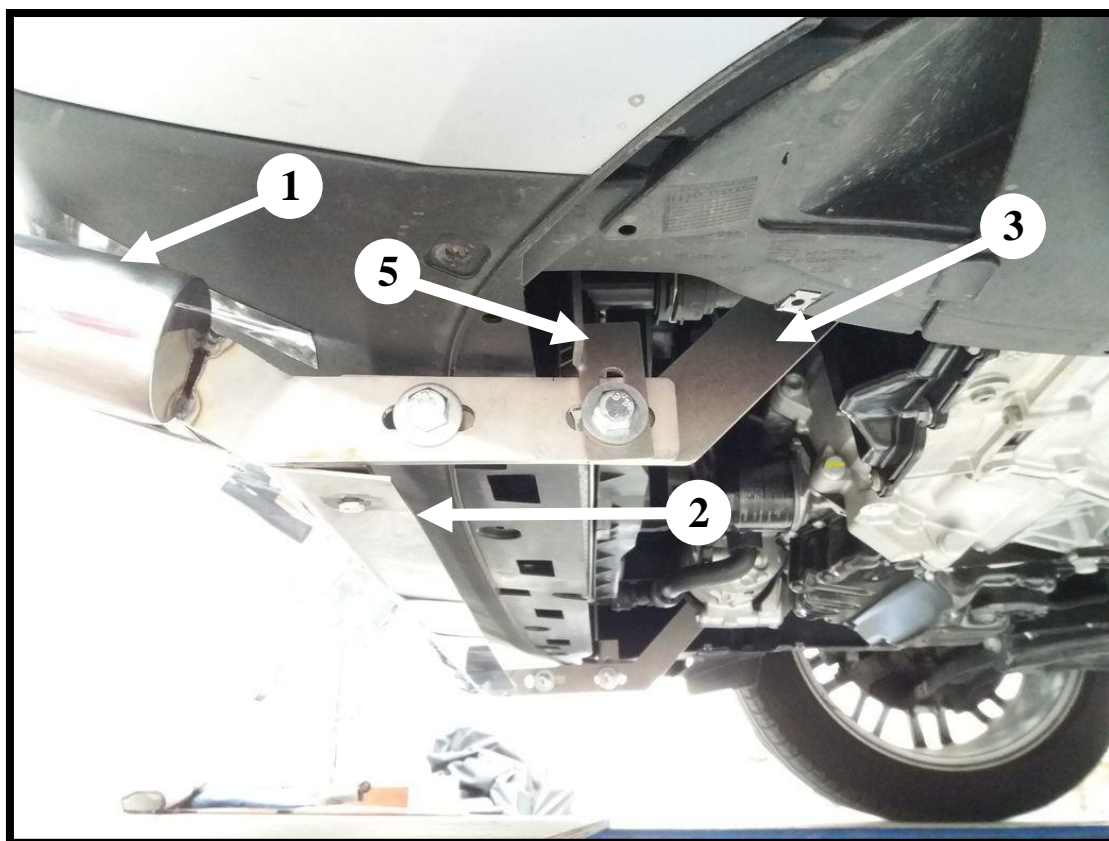
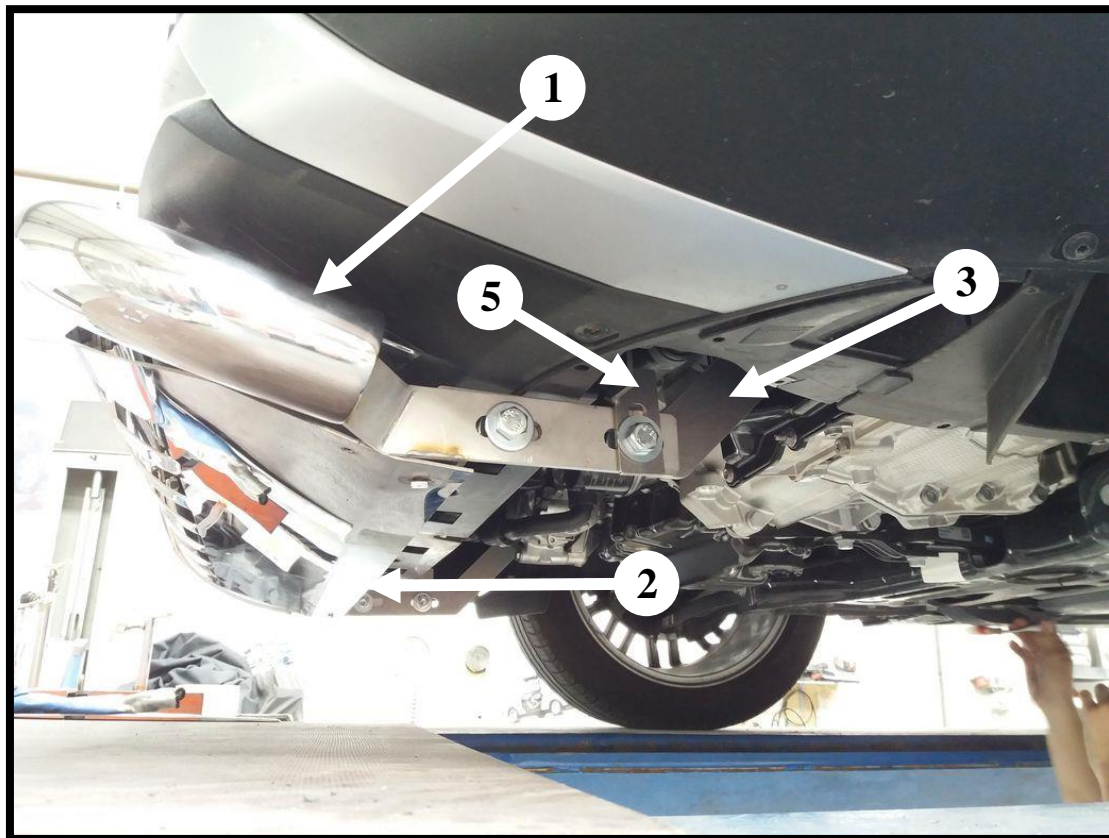

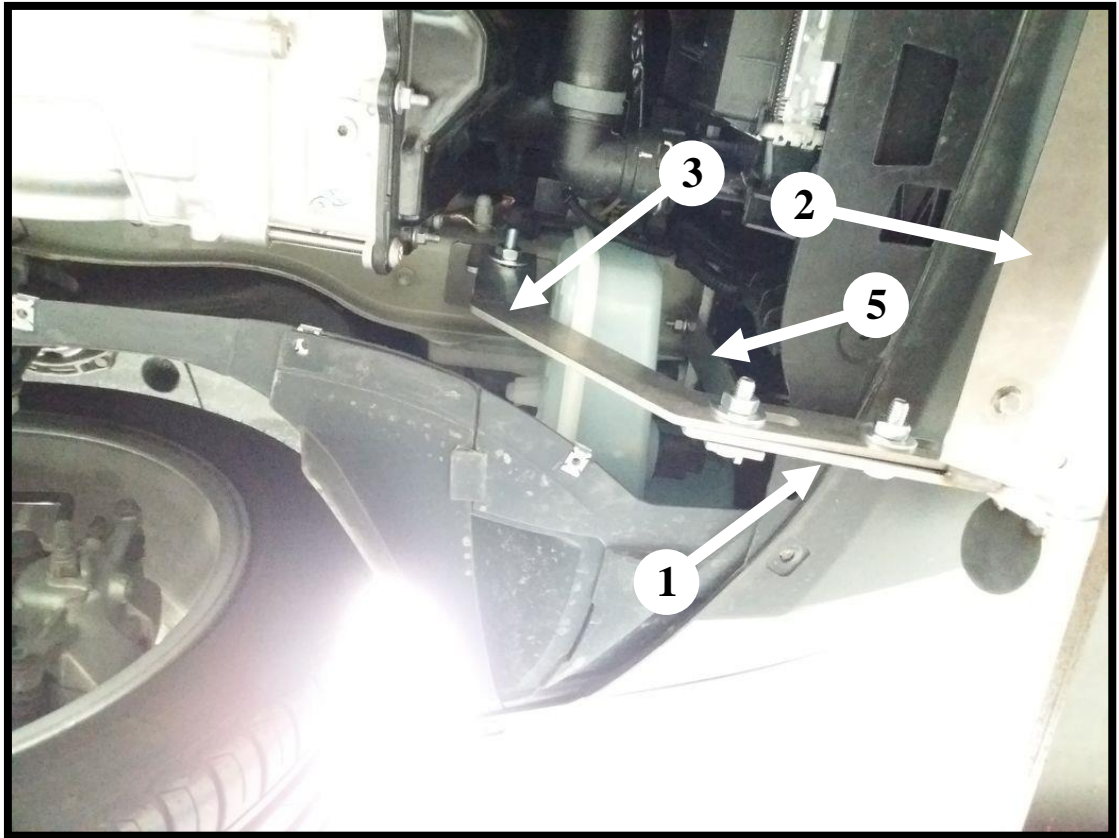

Prawa część orurowania / Right attachments / Правая часть защиты / Rechte Seite des Frontschutzbügels

