

\*For more info about compatibility with other models  
please see the sticker on the skid plate

## VOLKSWAGEN CADDY

No.: 5107.1 Engine block

Body: All  
Year: 2006-  
Engine: All  
Transmission: All

## FITTING KIT

1. Bolt M6x20.....	1 pc
2. Bolt M6x25.....	2 pc
3. Bolt M8x25.....	3 pc
4. Bolt M10x25.....	2 pc
5. Bolt M10x30.....	2 pc
6. Washer 6.....	3 pc
7. Washer 8.....	3 pc
8. Washer 10.....	4 pc
9. Insert nut M10x100/20.....	2 pc
10. Left bracket.....	1 pc
11. Right bracket.....	1 pc
12. Bushing h=6mm.....	2 pc

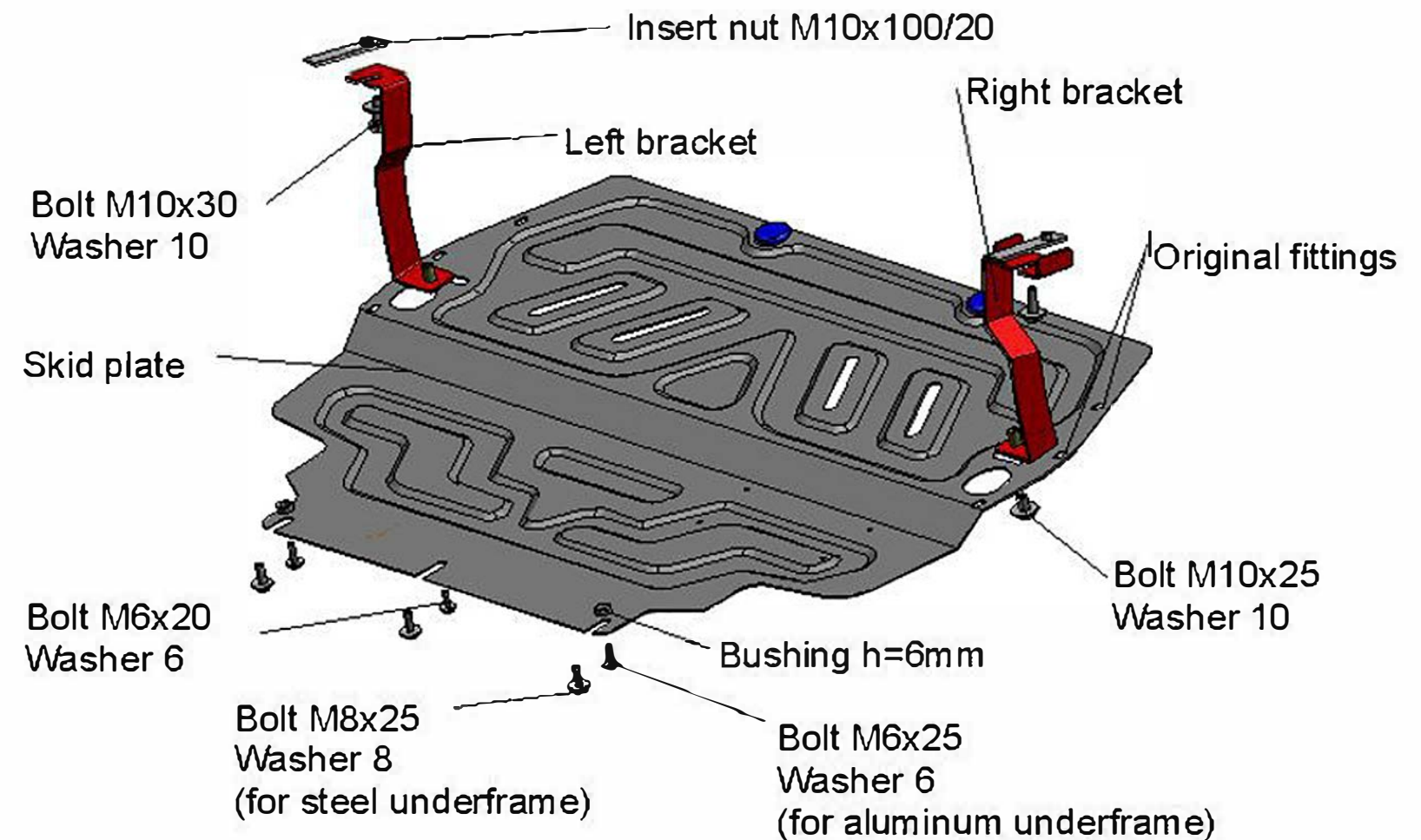

## INSTALLATION INSTRUCTIONS

1. Remove original guard.
2. Mount insert nuts M10x100/20 with bolts M10x30 into apertures of longerons.
3. Fix the brackets to mounted bolts M10x30.
4. For aluminum underframe: screw bolt M6x20 into the central threaded aperture of the underframe.  
For steel underframe: screw bolt M8x25 into the central threaded aperture of the underframe.
5. Put rear end of the skid plate on mounted bolt, then fix its front end to the brackets.
6. For aluminum underframe: fix rear fitting points of the skid plate with bolts M6x25 through the bushings h=6mm.  
For steel underframe: fix rear fitting points of the skid plate with bolts M8x25 through the bushings h=6mm.
7. Tighten all screws (50 Nm for M10, 30 Nm for M8, 10 Nm for M6). Use of pneumatic tools is prohibited.

