



STEELER

SOKÓŁKA

www.steeler.pl

TOYOTA PROACE VERSO 2016



INSTRUKCJA MONTAŻU

(Orurowania przednie rozłożyste)

FITTING INSTRUCTION

(Extensive front bullbar)

Инструкция монтажа

(кенгурин широкий)

MONTAGEANLEITUNG

(Frontschutzbügel)

PROACE-L1660-05-VERSO





Orurowania z homologacją „e”

Bullbar with homologation „e”

Тюнинг с омологацией „e”

Frontschutzbügel mit „e“- Prüfzeichen

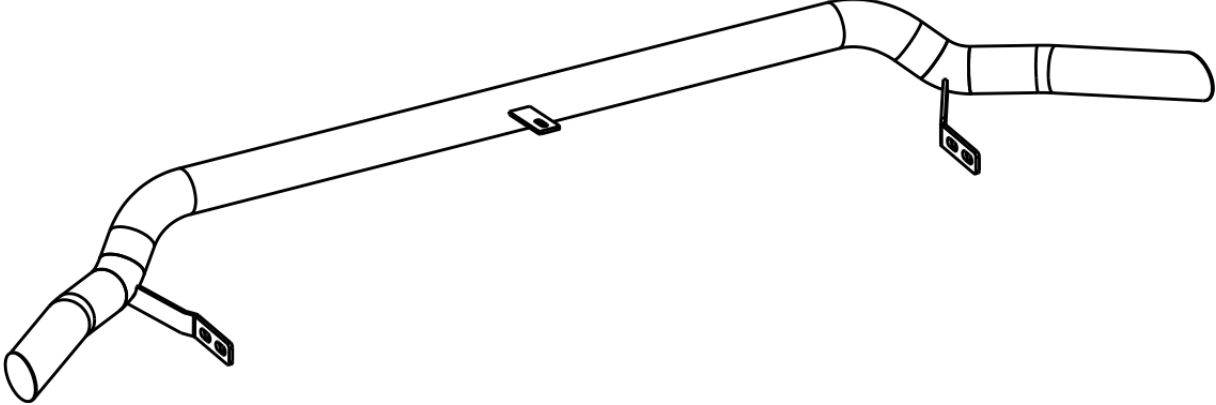
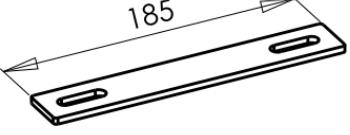
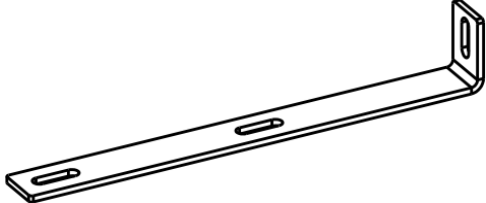
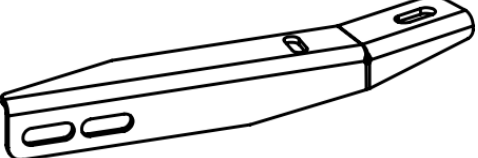
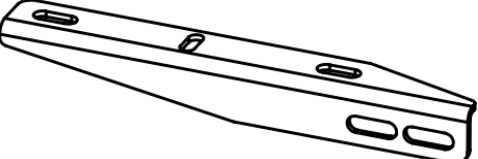
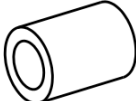
Wykaz elementów orurowania:
Specification of full assembly:
Список элементов тюнинга:
Liste der Elemente:

<p>1. Rura przednia (szt. 1) Bullbar (1 pc.) Передняя дуга (шт.1) Frontbügel (st.1)</p>	
<p>2. Zamocowanie górne I (szt.1) Upper attachment I (1 pc.) Крепление верхнее I (шт.1) Montage oben I (st.1)</p>	
<p>3. Zamocowanie górne II (szt.1) Upper attachment II (1 pc.) Крепление верхнее II (шт.1) Montage oben II (st.1)</p>	
<p>4. Zamocowanie dolne lewe (szt. 1) Lower left attachment (1 pc.) Крепление нижнее левое (шт.1) Montage unten links (st.1)</p>	
<p>5. Zamocowanie dolne prawe (szt. 1) Lower right attachment (1 pc.) Крепление нижнее правое (шт.1) Montage unten rechts (st.1)</p>	
<p>6. Dystans (szt.2) Distance (2 pcs.) Ø22x4 L=30 Расстояние (шт.2) Distanzring (st.2)</p>	
<p>7. Dystans (szt.4) Distance (4 pcs.) Ø21,3x2,6 L=10 Расстояние (шт.4) Distanzring (st.4)</p>	

Wykaz elementów łącznych:
Connecting components:
Список соединительных элементов:
Die Auflistung der Elemente:

Śruby (szt.) Screws (pcs.) Болты (шт.) Schrauben (st.)	M8x25 – (1) M8x50 – (4) M8x70 – (2) M10x35 – (4)	Nakrętki (szt.) Nuts (pcs.) Гайки (шт.) Muttern (st.)	M8 – (3) M10 – (4) M8 – (2) Nitonakrętka – Blind rivet nut
Podkładki (szt.) Washers (pcs.) Шайбы (шт.) Unterlegscheiben(st.)	Ø 8 – (6) Ø 8 – (4) – XL Ø 8 – (7) – SPR Ø 10 – (8) – XL Ø 10 – (4) – SPR	 13 17	

M6 - 7 Nm	M8 - 17 Nm	M10 - 33 Nm	M12 - 57 Nm
-----------	------------	-------------	-------------



1 h

Czas montażu
Fitting time
Время монтажа
Montagezeit

UWAGA: Folię usunąć dopiero po montażu!

ATTENTION: Foil remove after fitting!

ВНИМАНИЕ: Целлофан снять только после завершения монтажа!

HINWEIS: Die Folie soll erst nach der Montage entfernt werden!

Montaż orurowania / Bullbar fitting / Монтаж защиты / Montage der Schwellerrohre
PROACE-L1660-05-VERSO

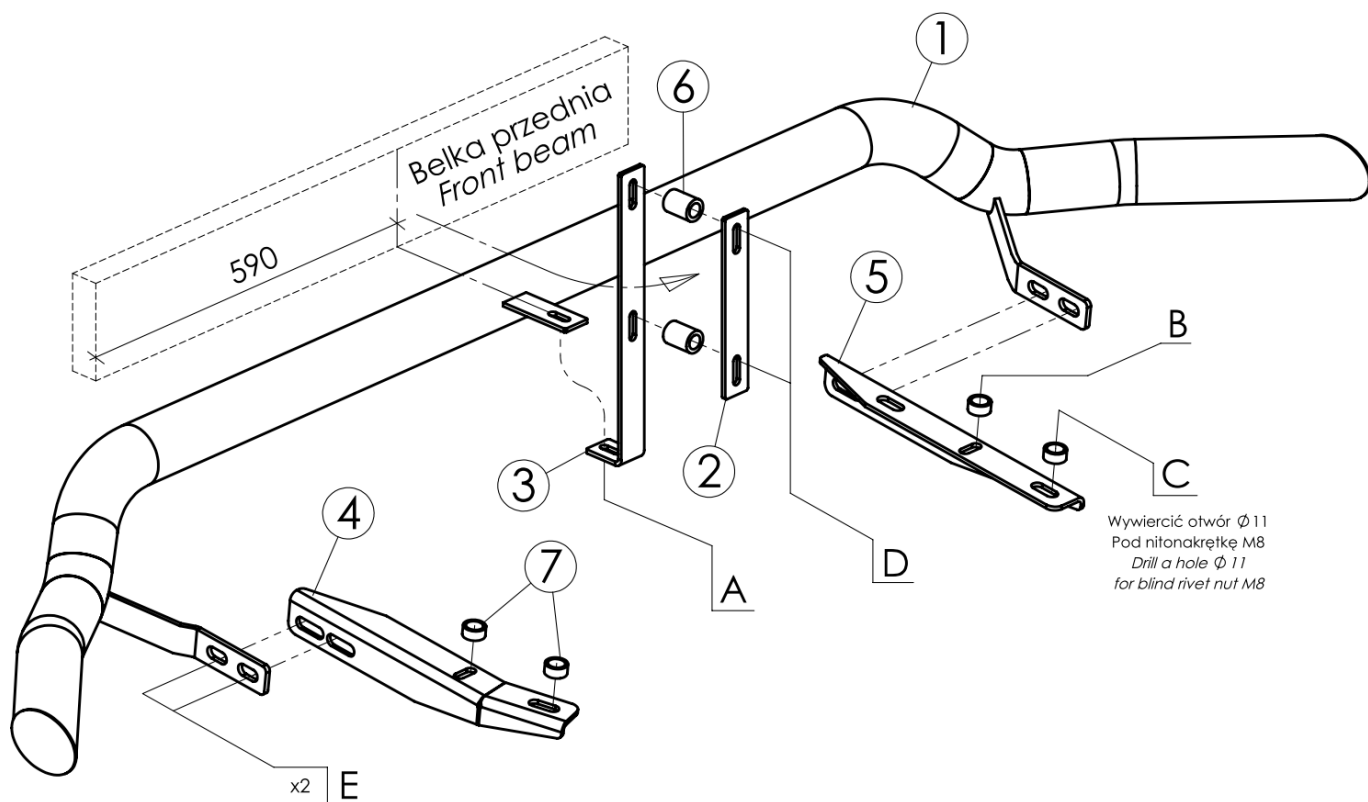

8,3 kg

	Śruby (szt.) Screws (pcs.) Болты (шт.) Schrauben (st.)	Podkładki (szt.) Washers (pcs.) Шайбы (шт.) Unterlegscheiben (st.)	Nakrętki (szt.) Nuts (pcs.) Гайки (шт.) Muttern (st.)
A	M8x25	Ø8(x2) Ø8-SPR	M8
B	M8x50	Ø8-SPR Ø8-XL	-----
C	M8x50	Ø8-SPR Ø8-XL	M8 (nitonakrętka – blind rivet nut)
D	M8x25	Ø8(x2) Ø8-SPR	M8
E	M10x35	Ø10-XL(x2) Ø10-SPR	M10

*Prawa część orurowania / Right attachments / Правая часть
защиты / Rechte Seite des Frontschutzbügels*

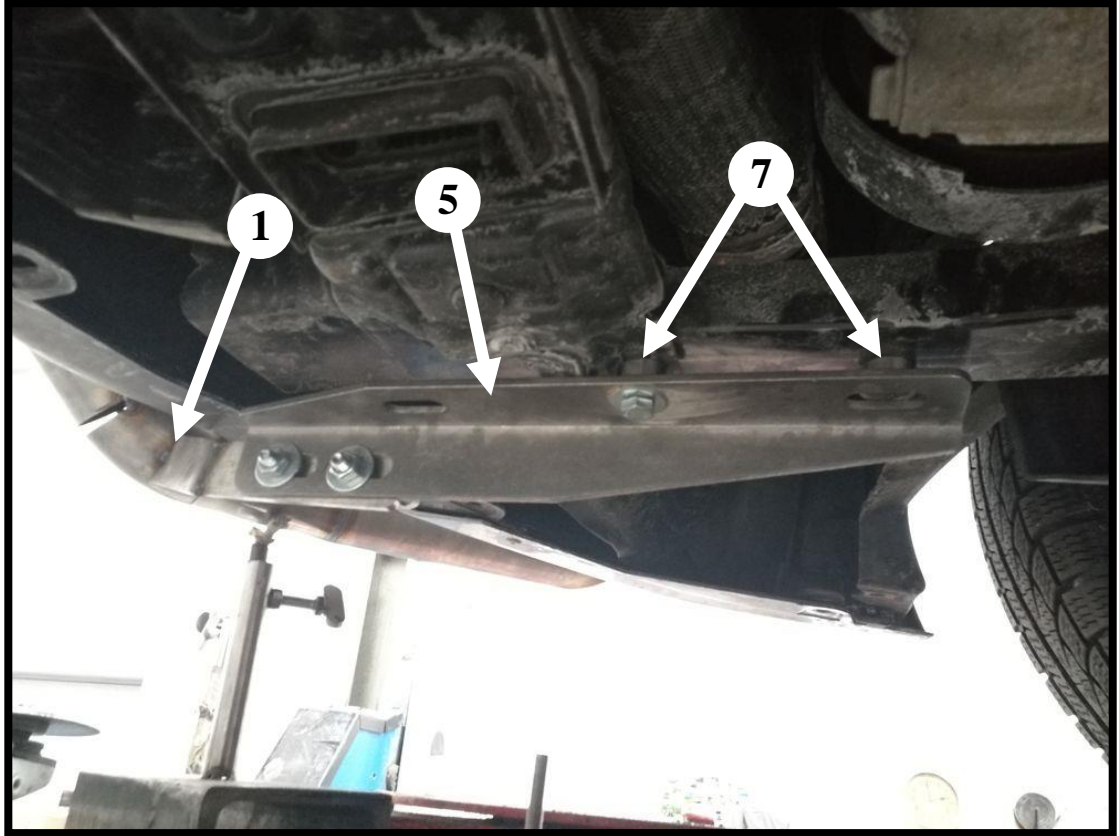

Wiercić otwór $\varnothing 11$ pod nitonakrętkę M8
Drill $\varnothing 11$ hole for M8 blind rivet nut

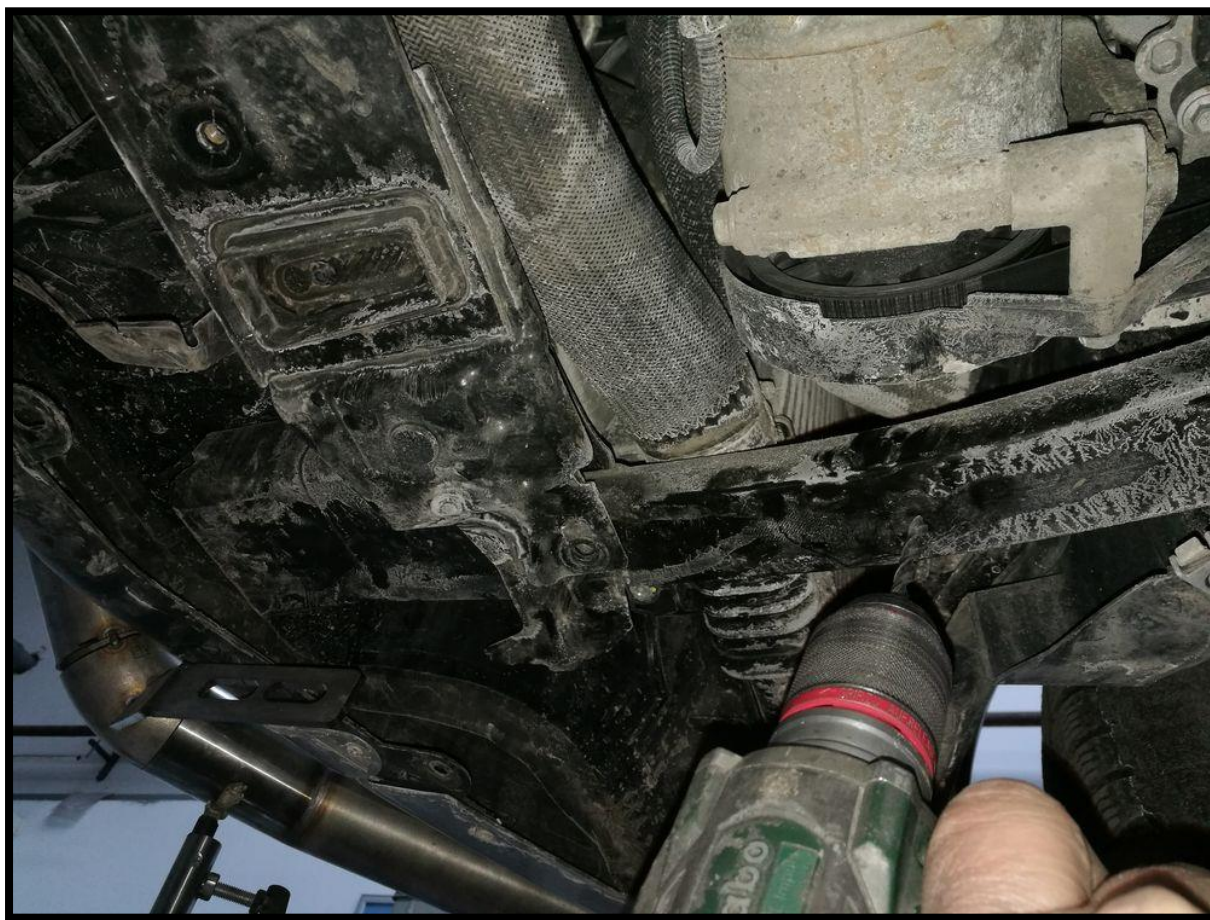



*Lewa część orurowania / Left attachments / Левая часть защиты
/Linke Seite des Frontschutzbügels*

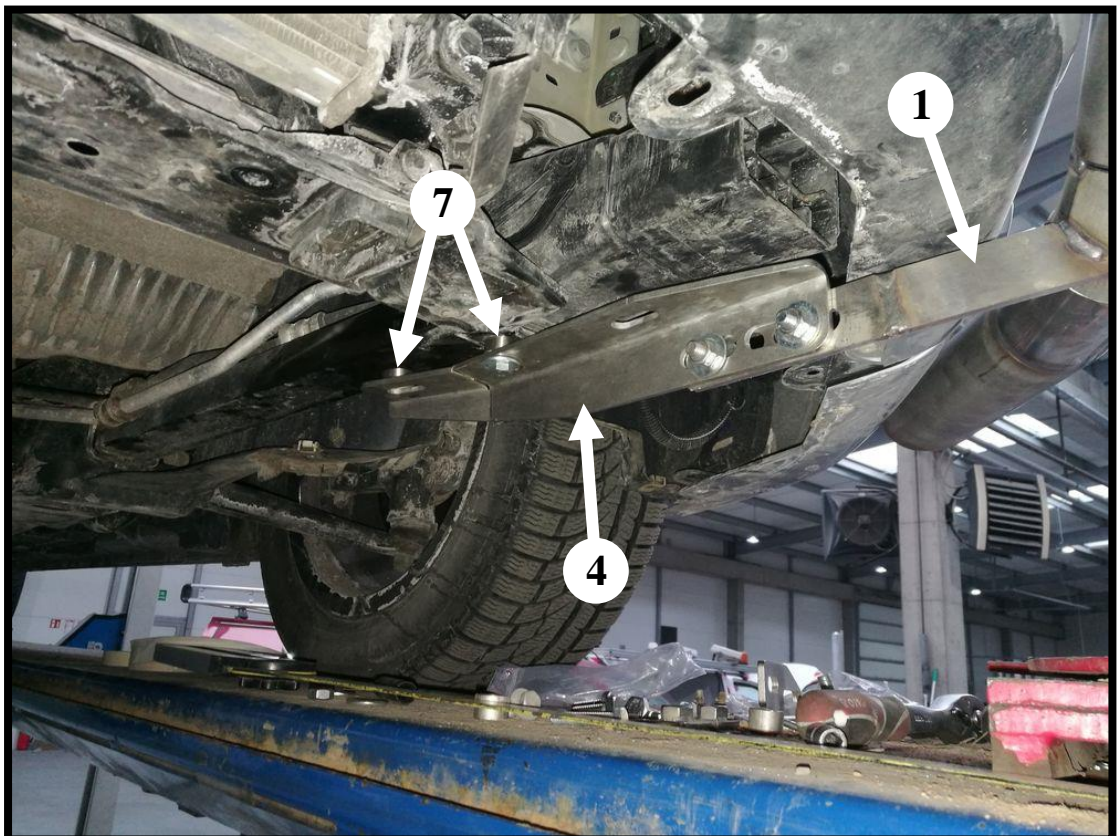
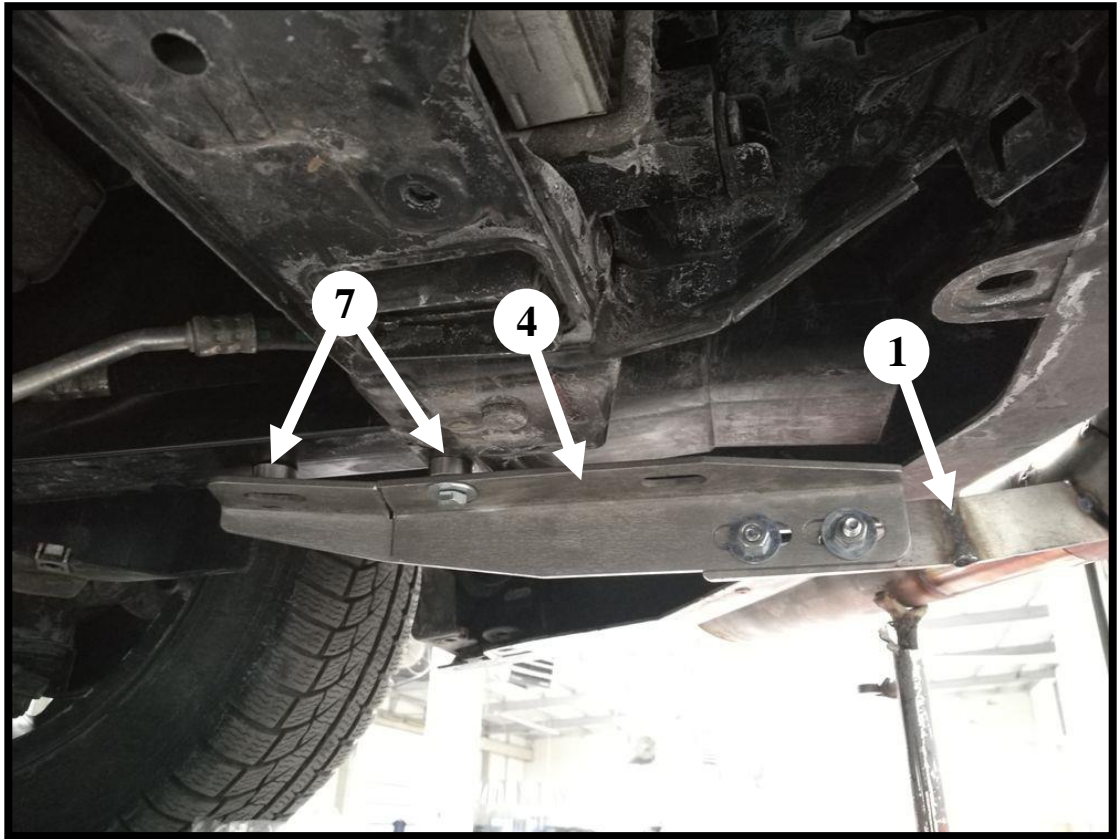

*Środkowa część orurowania / The middle part of the piping
/ Медиана часть защиты / Mittlere Befestigungen*

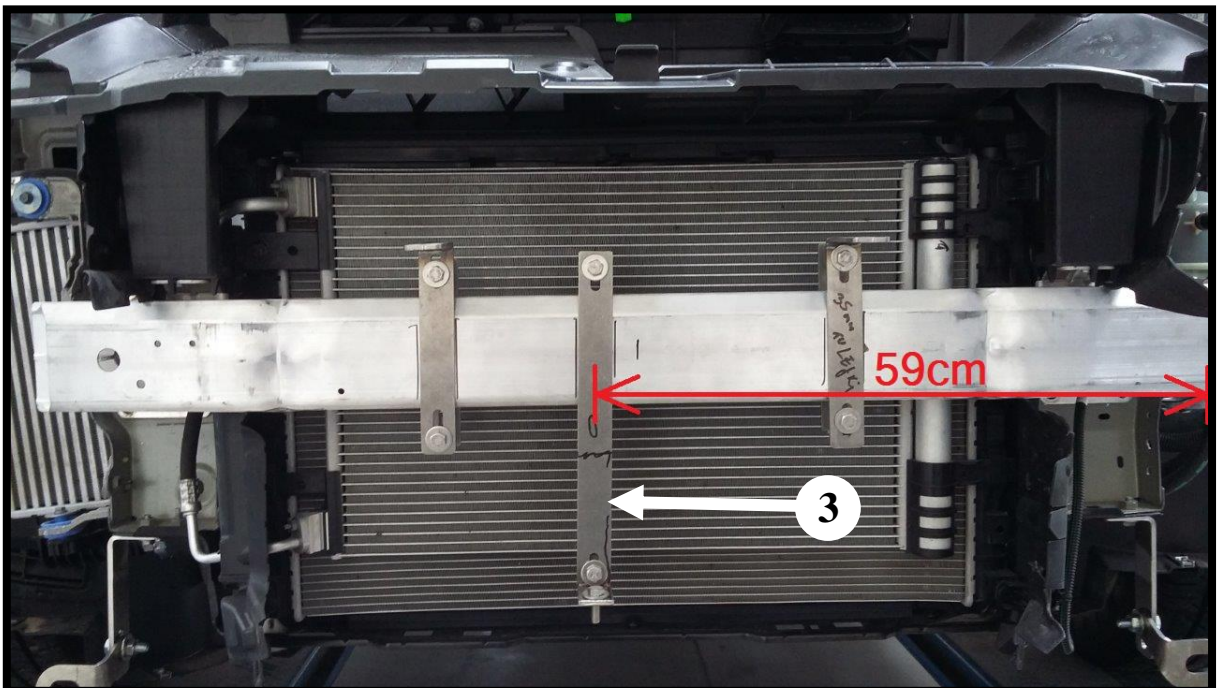
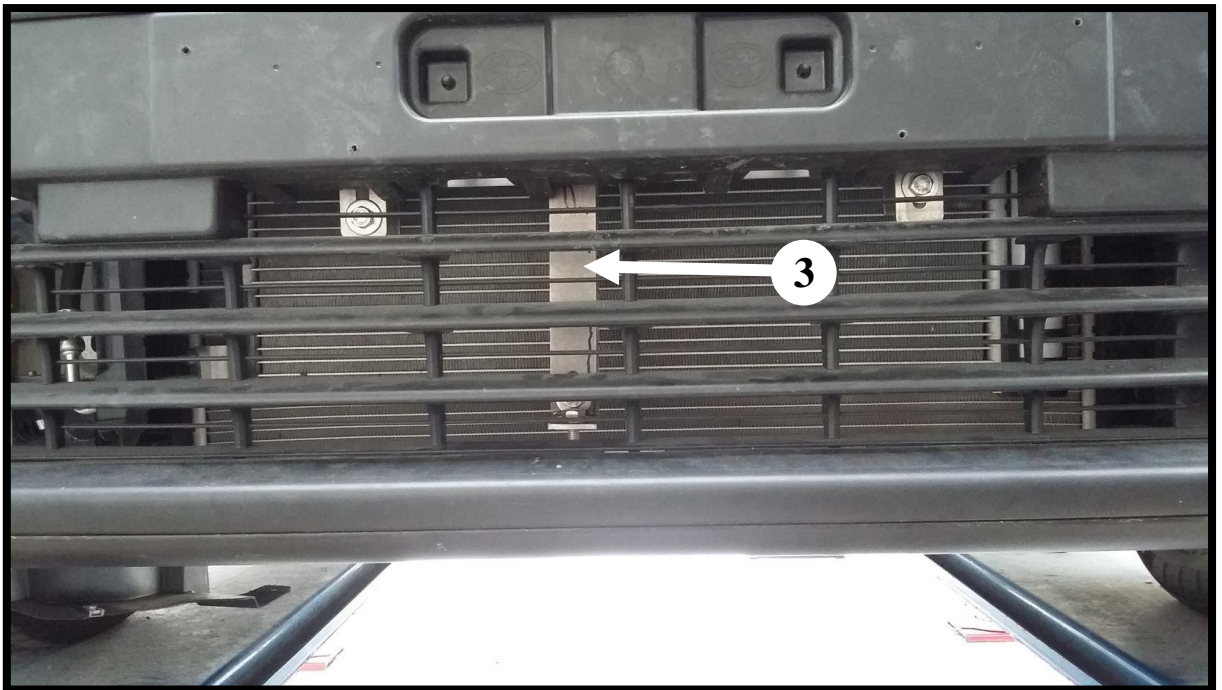

Widok dolny belki przedniej
Down view of the front beam

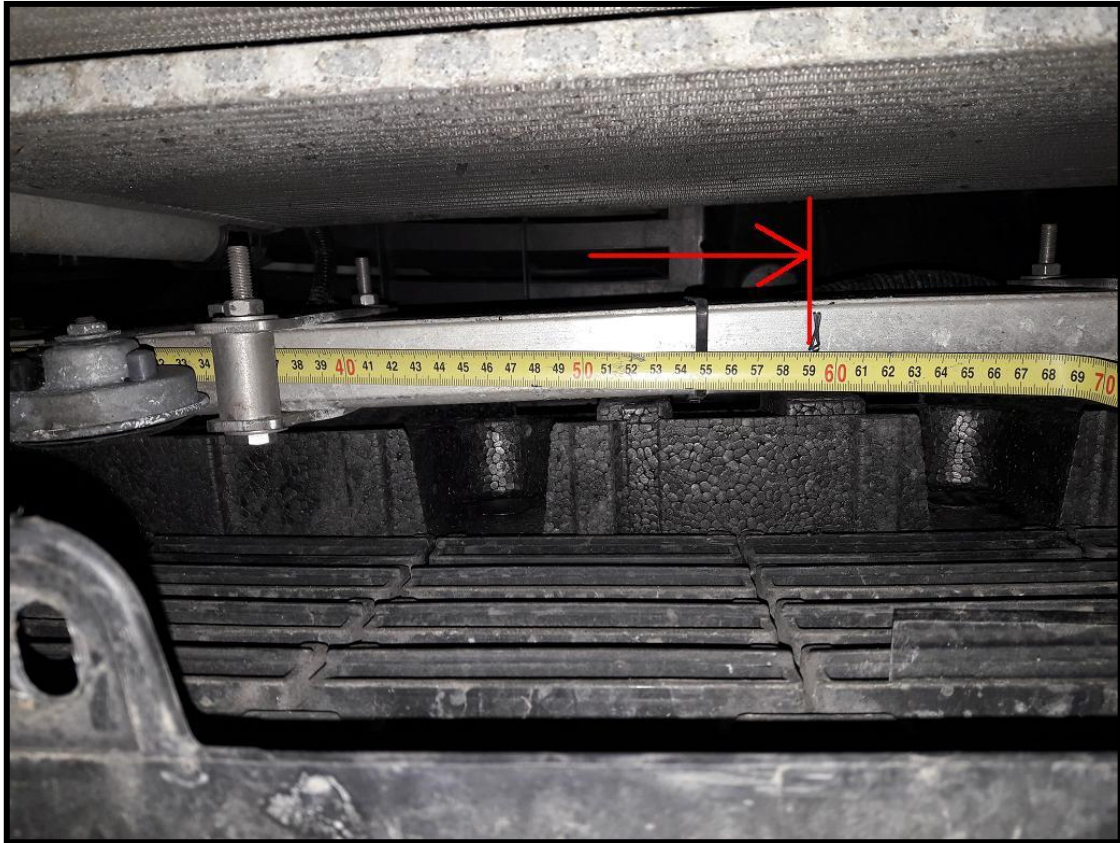

Dopasowanie osłony dolnej do zamocowań
Adjustment of the bottom cover for attachments







