

17W 4217

Fiat Fullback, Md. 2016

EU-Spoilerschutzrohr 60 mm gekröpft mit Unterfahrschutzblech

EU-Spoiler protective tube 60 mm cranked with underride guard plate

Tube de protection du spoiler vinklad CE 60 mm avec avant plaque

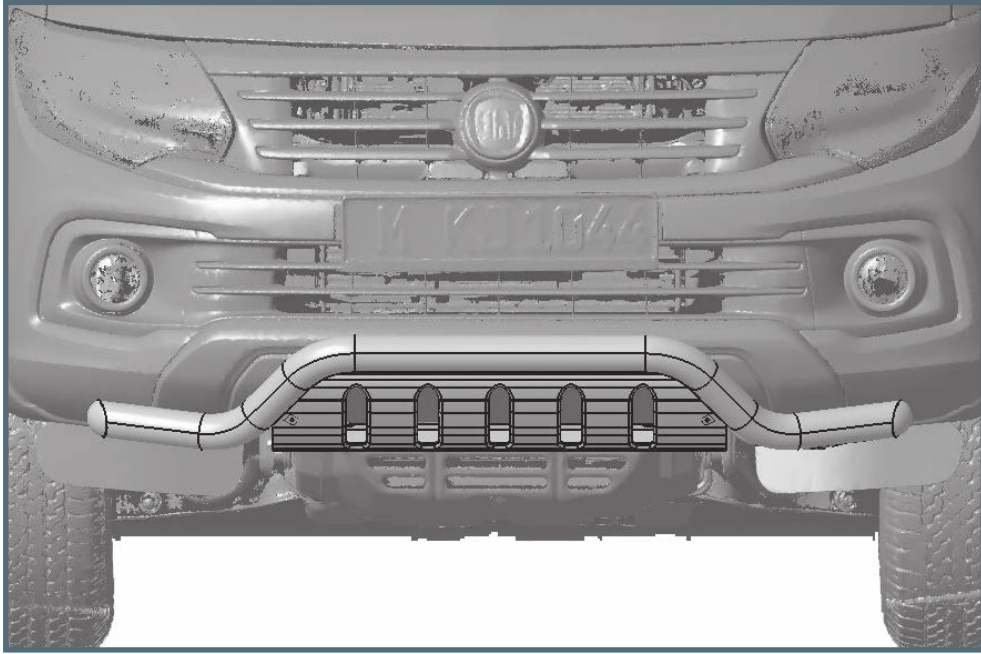

ASSEMBLY INSTRUCTION

Montageanleitung • Instructions de montage

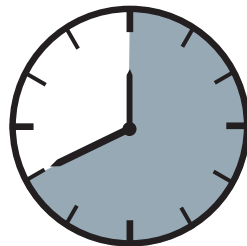

40 Minuten

Artikel-Nr:
17W4217 Stainless Steel
17W5217 Steel black

Revision 2: 17.01.2017



M8 (A2):
21,4 Nm
M8:
25 Nm
M10:
50 Nm



13
17

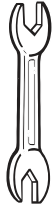

5

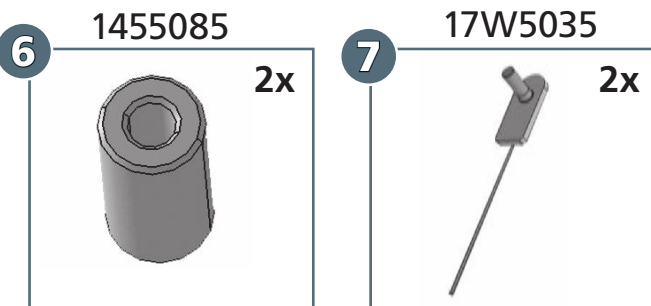
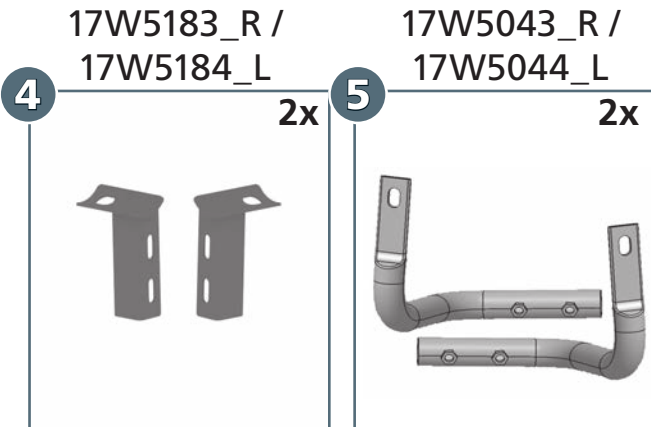
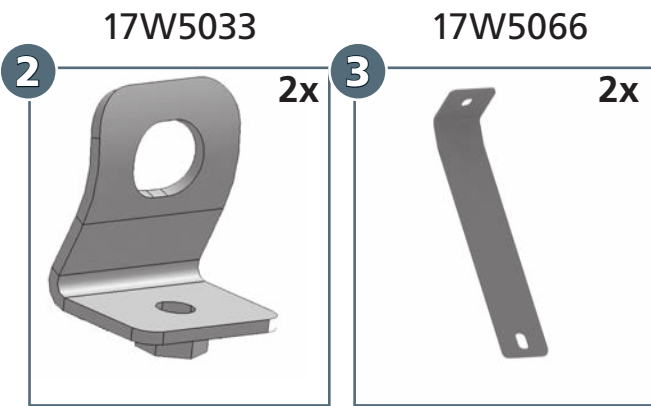
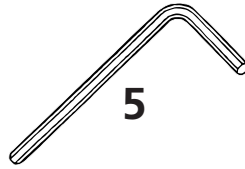

a		M8x20; ISO 7380 Zn	2x
b		M8x25; DIN 933 Zn	4x
c		M8x20; DIN 933 A2	2x
d		M8x30; DIN 933 A2	2x
e		M8x60; DIN 933 A2	2x
f		M10x85; DIN 933 Zn	2x
g		M8; DIN 934 Zn	2x
h		M10; DIN 934 Zn	2x
i		Ø 8; DIN 127 Zn	6x
j		Ø 8; DIN 127 A2	8x
k		Ø 10; DIN 127 Zn	2x
l		Ø 8,4; DIN 9021 Zn	6x
m		Ø 8,4; DIN 9021 A2	8x
n		Ø 10,5; DIN 9021 Zn	4x
o		SW 13	2x

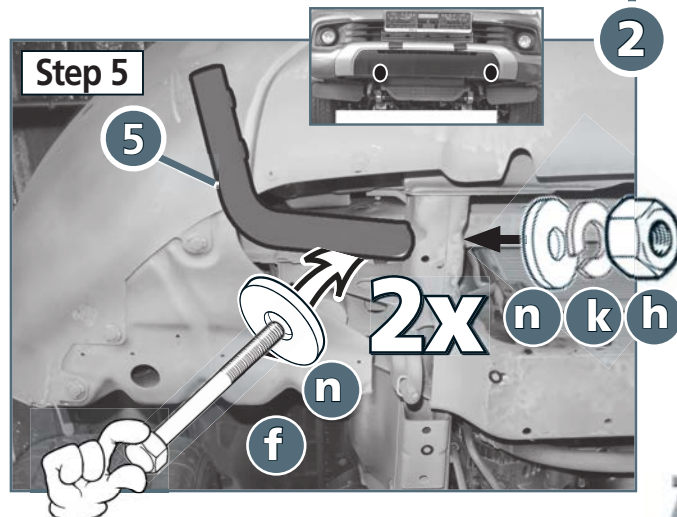
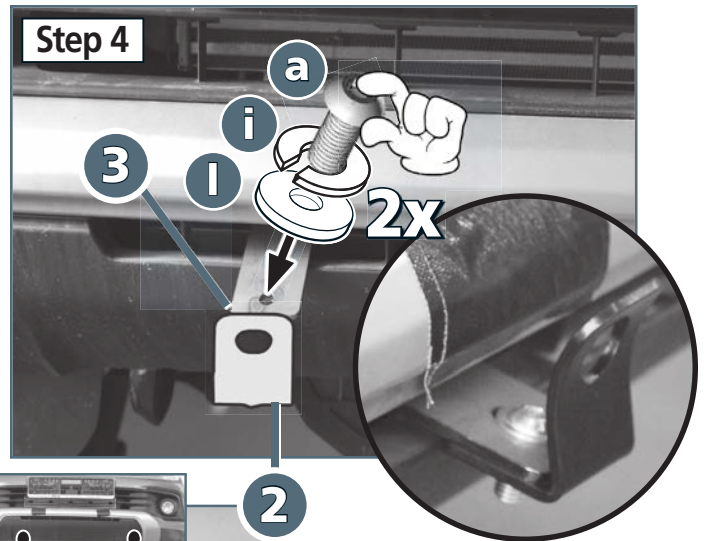
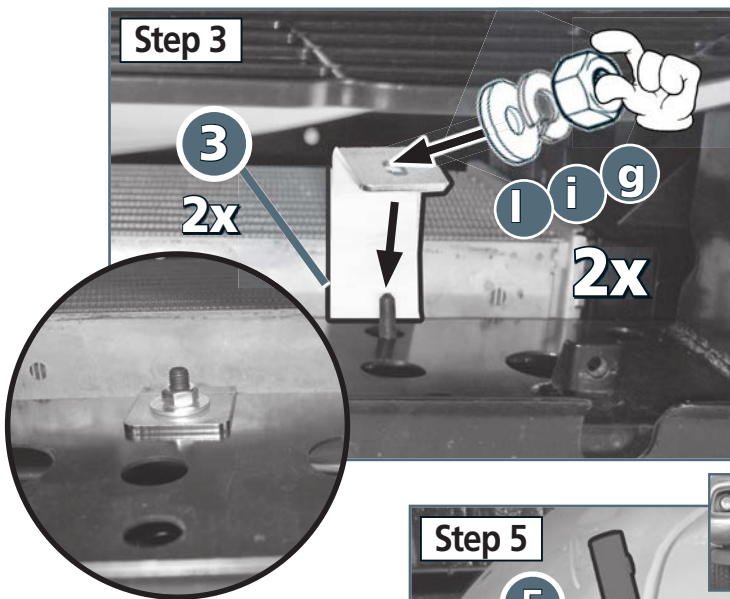
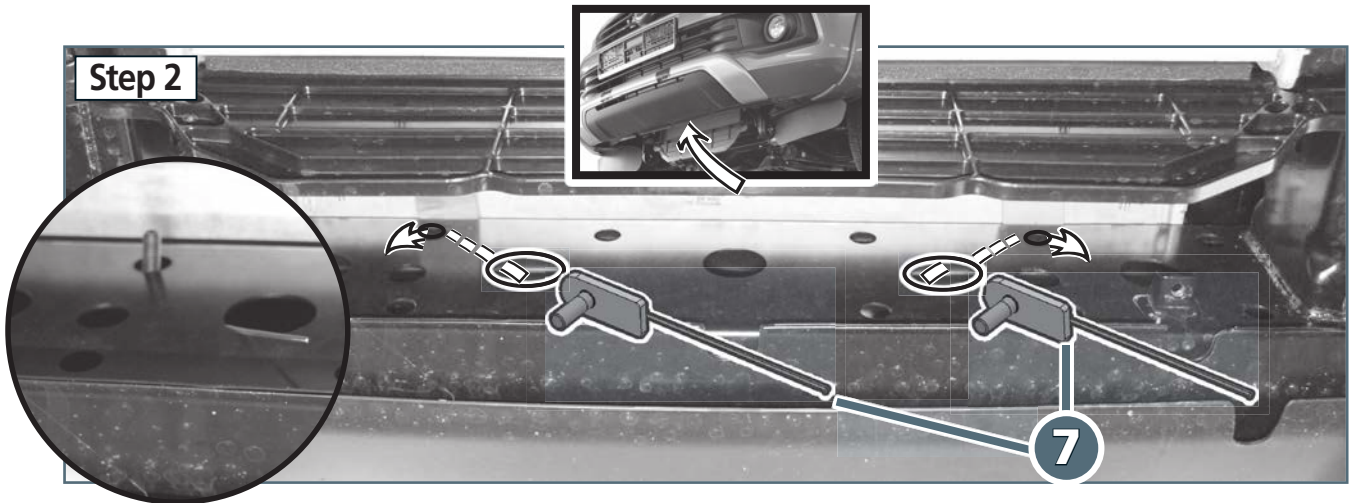
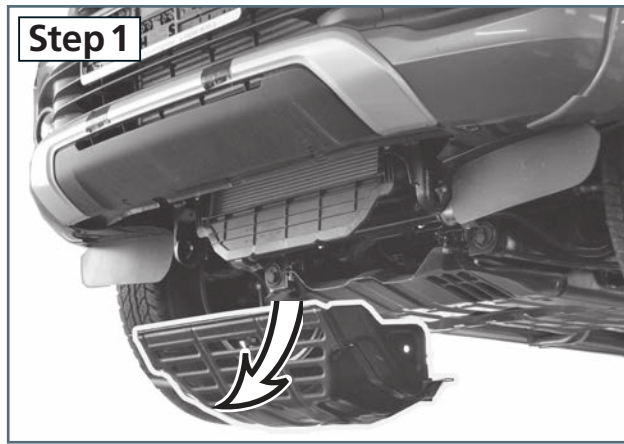

Revision 2: 17.01.2017



