

18N 4016

Mercedes X-Klasse, Md. 2016

EU-spoiler protection tube 51 mm

EU-Spoilerschutzrohr 51 mm

Tube de protection du spoiler, CEE 51 mm



*Compatible with Automatic Cruise Control /Forward Collision Mitigation
Kompatibel mit Abstandsregeltempomat /Auffahrvermeidungs-oder warnsystem
compatible avec radar de régulation de distance/ freinage autonome d'urgence



ASSEMBLY INSTRUCTION

Montageanleitung • Instructions de montage

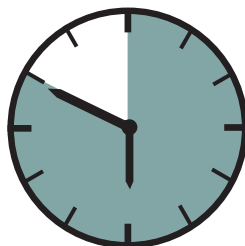

50 Minuten

article no.:

18N4016 (S) inox

18N5016 black steel

Revision 3: 04.10.2018



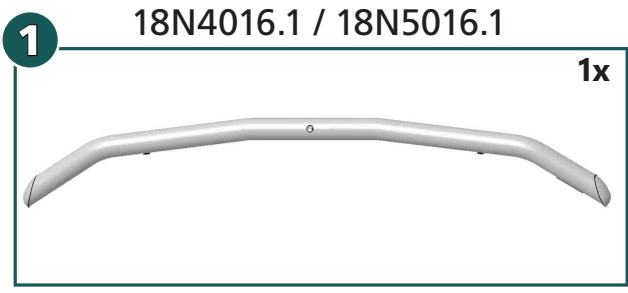
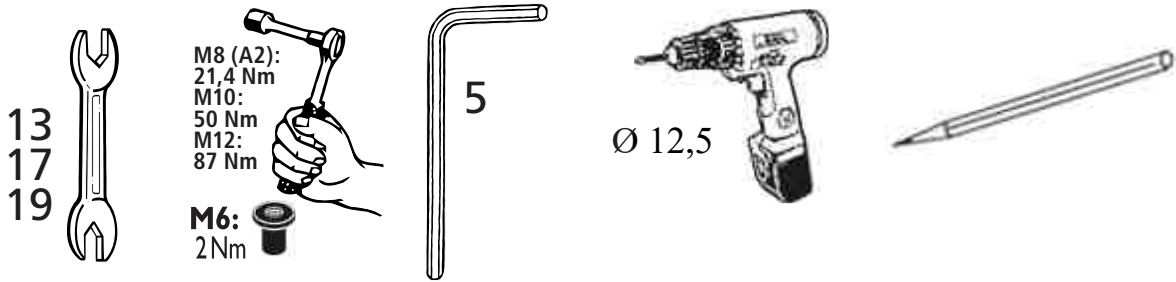

mounting kit: 18N9016

	M6x25; DIN 912 A2	1x
	M8x25; DIN 933 A2	2x
	M12x55; DIN 933 Zn	1x
	M10; DIN 934 Zn	2x
	M12; DIN 934 Zn	1x
	Ø 6; DIN 127 A2	1x
	Ø 8; DIN 127 A2	2x
	Ø 10; DIN 127 Zn	2x
	Ø 12; DIN 127 Zn	1x
	Ø 6,4; DIN 125 A2	1x
	Ø 8,4; DIN 9021 A2	2x
	Ø 10,5; DIN 9021 Zn	2x
	Ø 13; DIN 9021 Zn	2x
	Getowell M6	1x

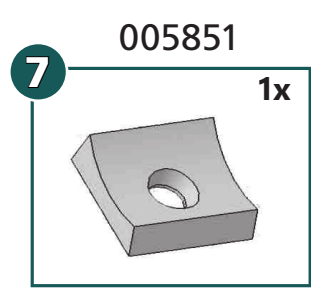
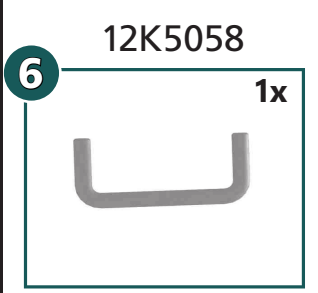
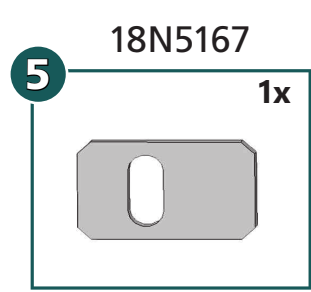
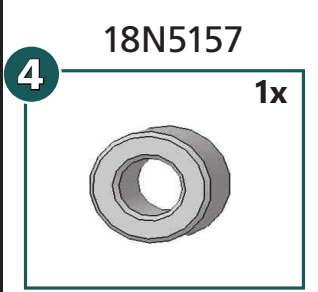
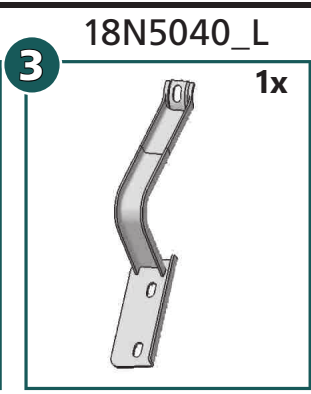
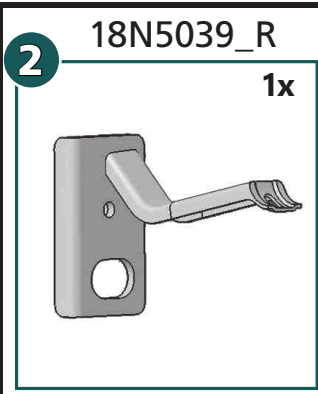

article no.:
 18N4016 (S) inox
 18N5016 black steel

Revision 3: 04.10.2018



